

**TECHNICAL SPECIFICATION
FOR
STEEL DRY CARGO CONTAINER
20' x 8' x 8'6" ISO 1CC TYPE
(BOTH END DOORS)**

I. General

1.1 Scope

This specification will cover the design, construction, materials, testing and inspection performances of 20' x 8' x 8'6" ISO 1CC type double end door containers.

These containers specified herein will be manufactured at _____ under strict quality control by _____ and be approved by the classification society or agency.

1.2 Operational environment

The container will be designed and constructed for carriage of general cargo by marine (on or below deck), road and rail throughout the world. All materials used in the construction will be to withstand extremes of temperature range from -30°C (-22°F) to +80°C (+176°F) without effect on the strength of the basic structure and watertightness.

1.3 Standards and Regulations

The container will satisfy the following requirements and regulations, unless otherwise mentioned in this specification.

1.3.1 ISO Container Standards (1CC type)

- ISO 668 -- Series 1 freight containers - Classification external dimensions and ratings [Amd. 1993 (E)]
- ISO 830 -- Terminology in relation to freight container (Amd. 1988)
- ISO 1161 -- Series 1 freight containers - Corner fittings Specification (Amd. 1990)
- ISO 1496-1 -- Series 1 freight containers - Specification and testing.
part 1: General cargo containers for general purposes (Amd.2 - 1998)
- ISO 6346 -- Freight containers - coding, identification and marking - 1995(E)
- ISO 3874 -- Series 1 freight containers - Handling and Securing (1988)

1.3.2 T.I.R. Certification

All the containers will be certified and comply with "The Customs Convention on the International Transport of Goods under the cover of T.I.R. Carnets." or "The Customs Convention on Containers."

1.3.3 C.S.C. Certification

All the containers will be certified and comply with the requirements of the "International Convention for the Safe Containers."

1.3.4 T.C.T. Certification

All exposed wooden components used for container will be treated to comply with the requirements of "Cargo Containers - Quarantine Aspects and Procedures" of the Commonwealth Department of Health, Australia.

1.3.5 U.I.C. Registration

All the containers will be registered and comply with the "International Union of Railways." code 592-2.

1.3.6 Classification society

All the containers will be certified for design type and individually inspected by classification society, **CCS, BV, ABS, LR, or GL**

Note:	CCS	:	China Classification Society (<i>P.R.C</i>)
	BV	:	Bureau Veritas (<i>France</i>)
	ABS	:	American Bureau of Shipping (<i>USA</i>)
	LR	:	Lloyd's Register of Shipping (<i>UK</i>)
	GL	:	Germanischer Lloyd (<i>Germany</i>)

1.4 Handling

The container will be constructed to be capable of being handled without any permanent deformation under the following conditions:

- a) Lifting, full or empty, at top corner fittings vertically by means of spreaders fitted with hooks, shackles or twistlocks.
- b) Lifting, full or empty, at bottom corner fittings using slings with terminal fittings at any angles between vertical and 45 degrees to the horizontal.
- c) Lifting, full or empty, at forklift pockets using forklift truck.

1.5 Transportation

The container will be constructed to be suitable for transportation in the following modes:

- a) Marine : In the ship cell guides of vessels, seven (7) high stacked.
On the deck of vessels, four (4) high stacked and secured by vertical and diagonal wire lashings.
- b) Road : On flat bed or skeletal chassis, secured by twistlocks or equivalent at the bottom corner fittings.
- c) Rail : On flat cars or special container cars secured by twistlocks or equivalent at the bottom corner fittings.

2. Dimensions and Ratings

2.1 External Dimensions

Length	6,058	+ 0mm - 6mm	19'10 1/2"	+0 -1/4"
Width	2,438	+ 0mm - 5mm	8'	+0 -3/16"
Height	2,591	+ 0mm - 5mm	8'6"	+0 -3/16"

- 1) No part of the container will protrude beyond the external dimensions mentioned above.
- 2) Maximum allowable differences between two diagonals on anyone of the following surfaces will be as follows:
 Roof, bottom and side diagonals : 13mm 1/2"
 Front and rear diagonals : 10mm 3/8"

2.2 Internal Dimensions

Length	5,844	+ 0mm - 6mm	19' 2 5/64"	+0 -1/4"
Width	2,352	+ 0mm - 5mm	7' 8 19/32"	+0 -3/16"
Height	2,393	+ 0mm - 5mm	7'10 7/32"	+0 -3/16"

2.3 Door opening dimensions

Width	2,340	+ 0mm - 5mm	7' 8 1/8"	+0 -3/16"
Height	2,280	+ 0mm - 5mm	7' 5 49/64"	+0 -3/16"

2.4 Internal cubic capacity (Nominal)

32.9 cu.m 1,160 cu.ft

2.5 Forklift pockets

Width	360 mm	1' 2 11/64"
Height min.	115 mm	4 1/2"
Centre to centre	2,080 mm +20/- 80mm	6' 9 57/64 +25/32"/ -3 5/32"

2.6 Ratings

Max. Gross Weight (R)	30,480 kgs	67,200 lbs
Tare Weight (design) (T)	2,310 kgs	5,090 lbs
Max. Payload (P)	28,170 kgs	62,110 lbs

Tare Weight Tolerance 2%

3. Materials3.1 General

The following materials will be used in the construction of containers.

3.2 Part specification

	<u>Parts</u>	<u>Materials by JIS</u>
1)	Roof panels Door panels Side panels Cross members Bottom side rails Top side rails Door sill Door header (upper & lower) Upper & lower plates of forklift pockets Door horizontal frames Door vertical frames Corner posts (outer)	Anti-Corrosive Steel: CORTEN A, SPA-H, B480 or equivalent Y.P. : 35 kg/sq. mm T.S. : 49 kg/sq. mm
2)	Corner posts (inner)	Rolled high tensile steel: SM490A or equivalent Y.P. : 33 kg/sq. mm T.S. : 50 kg/sq. mm
3)	Door locking bars	Structural steel round pipe: STK41 Y.P. : 24 kg/sq. mm T.S. : 41 kg/sq. mm
4)	Corner Fitting	Casted weldable steel: SCW480 Y.P. : 28 kg/sq. mm T.S. : 49 kg/sq. mm
5)	Locking gear cams and keepers	Forged weldable steel: S20C Y.P. : 23 kg/sq. mm T.S. : 44 kg/sq. mm
6)	Door hinge pins Door gasket retainers	Stainless steel: SUS304
7)	Door gasket	EPDM
8)	Floor board	Hardwood plywood, min. 19-ply
9)	Ventilator	ABS resin labyrinth type

* Note: Y.P. --- Yielding Point
T.S. --- Tensile Strength

4. Construction

4.1 General

- 4.1.1 The container will be constructed with steel frames, fully vertical-corrugated steel sides, horizontal-corrugated steel double doors at both end, die-stamped steel roof and corner fittings.
- 4.1.2 All welds of exterior including the base frames will be continuous welding using CO₂ gas, but inner part of each bottom side rail will be fastened by staggered stitch welding.
- 4.1.3 Interior welds - when needed - will be stitched with a minimum bead length of 15mm.
- 4.1.4 Gaps between adjacent components to be welded will not exceed 3mm or the half thickness of the parts being welded.
- 4.1.5 Chloroprene sealant is to be applied at periphery of floor surface and inside unwelded seams, butyl sealant is used to caulk at invisible seam of floor joint area and between door gasket and frame.
- 4.1.6 The wooden floor will be fixed to the base frames by zinc plated self-tapping screws.

4.2 Protrusion

- 4.2.1 The plane formed by the lower faces of the bottom side rails and all transverse members shall be positioned by 12.5mm +5/-1.5mm above the plane formed by the lower faces of the bottom corner fittings.
- 4.2.2 The top corner fittings are to protrude a minimum of 6mm above the highest point of the roof.
- 4.2.3 The outside faces of the corner fittings will protrude from the outside faces of the corner posts by minimum 4mm.
- 4.2.4 The outside faces of the corner fittings will protrude from the outside faces of the sides by nominal 8mm.
- 4.2.5 Under maximum payload, no part of the container will protrude below the plane formed by the lower faces of the bottom corner fittings at the time of maximum deflection.
- 4.2.6 Under 1.8 x maximum gross weight, no part of the container will protrude more than 6.0mm below the plane formed by the lower faces of the bottom corner fittings at the time of maximum deflection.

4.3 Corner fittings

The corner fittings will be designed in accordance with ISO 1161 (Amd.1990) and manufactured at the works approved by classification society.

4.4 Base frame structure

Base frame will be composed of two (2) bottom side rails, a set of forklift pockets and totally nineteen (19) cross members.

4.4.1 Bottom side rail

Each bottom side rail is built of 52x30x155x28x 4.5mm thick cold-formed double "Z" section steel made in one piece. The lower flange of the bottom side rail is outward so as to facilitate easy removal of the cross members during repair and of less susceptible corrosion.

Reinforcement plates are to be made of 4.0mm thick angle section steels. The angle steels are welded to bottom corner fitting.

4.4.2 Forklift pockets

Each forklift pocket is built of 3.0mm thick full depth flat steel top plate and two 200 mm deep x 6.0 mm thick flat lower end plates between two channel section cross members.

The one set of forklift pockets is designed in accordance with ISO requirements.

4.4.3 Cross member

The cross members are made of pressed channel section steel with a dimension of 45x122x45x4.0mm for the normal areas and 75x122x45x4.0mm for the floor butt joints. The cross members are placed fully to withstand floor strength and welded to each bottom side rail. Three (3) pieces of 4.0mm gussets to be fully welded at one inside of floor joint cross-member.

4.5 Flooring

The floor will consist of six pieces plywood boards, floor centre rail, and self-tapping screws.

4.5.1 Floor

The wooden floor to be constructed with 28mm thick min.19-ply hardwood plywood boards which is the first three layers on top/bottom the grain should be in longitudinal direction are laid longitudinally on the transverse members and floor centre rail of 4.0mm thick flat bar. The floorboards are tightly secured to each transverse member by self-tapping screws, and all butt joint areas and peripheries of the floorboards are caulked with sealant.

- 1) Wood species : Apitong or Tropical combination hardwood plywood.
- 2) Glue : Phenol-formaldehyde resin.
- 3) Treatment :
 - a) Preservative: MEGANIUM 2000 or others.
 - b) In accordance with Australian Health Department Regulations. Average moisture content will be 12% before installation.

4.5.2 Self-tapping screw

Each floor board is fixed to the transverse members by zinc plated self-tapping screws that are 8.0mm dia. shank x 16mm dia. head x 45mm length, and fastened by four screws per cross member but five screws at joint areas. Screw heads are to be countersunk through about 2mm below the floor top surface.

4.6 Rear frame structure

The rear frame will be composed of one door sill, two corner posts, one door header and four corner fittings, which will be welded together to make the door-way.

4.6.1 Door sill

The door sill to be made of a 4.5mm thick pressed open section steel is reinforced by four internal gussets of a 4.0mm thick at the back of each locking cam keeper location. The upper face of the door sill has a 10mm slope for better drainage.

A 200 x 75mm section is cut out at each end of the door sill and reinforced by a 200 x 75mm channel steel as a protection against handling equipment damages.

4.6.2 Rear corner post

Each rear corner post of hollow section is fabricated with pressed, 6.0mm thick, steel outer part and 40x113x10mm hot-rolled channel section steel inner part, which are welded continuously together to ensure a maximum width of the door opening and to give a sufficient strength against stacking and racking forces.

Four (4) sets of hinge pin lugs are welded to each rear corner post.

4.6.3 Door header

The door header is constructed with a 4.0mm thick pressed "U" section steel lower part having four internal gussets at the back of each locking cam keeper location and a 3.0mm thick pressed steel upper part, which are formed into box section by continuous welding.

4.7 Door

4.7.1 Each container will have double wing doors at rear end frame, and each door will be capable of swinging approximately 270 degrees.

4.7.2 Each door is constructed with pressed, 3.0mm thick, channel section steel horizontal frames for the top and bottom, 100x50x3.2mm rectangular hollow section vertical frames for the post side and centre side of door respectively, 2.0mm thick horizontally corrugated steel door panel, which are continuously welded within frames.

4.7.3 Two sets of galvanized locking assemblies which is the same model with "SL-F/1", "HH-ET" or "SJ-66M" with steel handles (two point custom sealing system) are fitted to each door wing using high tensile zinc plated steel bolts according to TIR requirements. Locking bar retainers are fitted with nylon bushings at the top, bottom and intermediate bracket. Locking gears should be assembled after painting and not to be painted.

4.7.4 The left-hand door can not be opened without opening the right-hand door when the container is sealed in accordance with TIR requirements.

4.7.5 The door hold-back of nylon rope is provided to the centre locking bar on each door and a hook of steel bar is welded to each bottom side rail.

4.7.6 Each door is suspended by four hinges being provided with stainless steel pins, self-lubricating nylon bushings and brass washers, which are placed at the hinge lugs of the rear corner posts.

4.7.7 The door gasket made of an extruded triple lip type (J-C type - vertical and upper are "J", lower is "C") EPDM rubber with an increase lip at right door left top corner for better waterproof is installed to the door peripheral frames with stainless steel gasket retainers and fastened by stainless steel blind rivets at a pitch of about 150mm. The door gasket must be caulked with butyl sealant before installation to the door frames.

4.8 Roof structure

The roof will be constructed with five five-corrugated (die-stamped) steel panels and four corner protection plates.

4.8.1 Roof panel

The roof panel is constructed with 2.0mm thick die-stamped steel sheets having about 5.0mm upward smooth camber, which are welded together to form one panel and continuously welded to the top side rails and top end rails. All overlapped joints of inside unwelded seams are caulked with chloroprene sealant.

4.8.2 Protection plate

Each corner of the roof in the vicinity of top corner fitting is reinforced by 3.0mm thick rectangular steel plate to prevent the damage caused by mishandling of lifting equipment.

4.9 Top side rail

Each top side rail is made of a 60x60x3.0mm thick square hollow section steel.

4.10 Side wall

The trapezium section side wall is constructed with 1.6mm thick fully vertically continuous corrugated steel panels at the intermediate area and 2.0mm thick fully vertically continuous corrugated steel panels at both ends which are butt welded together to form one panel and continuously welded to the side rails and corner posts. All overlapped joints of inside are caulked with chloroprene sealant.

4.11 Special feature

4.11.1 Customs seal provisions

Customs seal and padlock provisions are made on each locking handle retainer to cover the sealed area in accordance with TIR requirements.

4.11.2 Lashing fittings

Five(5) Φ 12 lashing hoop rings are welded to each top and bottom side rail at recessed corrugations of side panels but not extruded any cargo space (total 20 rings). Each lashing point is designed to provide a "1,500 kgs pull load in any direction" without any permanent deformation of lashing ring and surrounding area.

Two (2) Φ 10 lashing rods are welded to each corner post. Each lashing rod on the corner post is designed to provide a "1,000 kgs pull load in any direction" without any permanent deformation.

4.11.3 Shoring slot

A shoring slot, having a size of 60 mm width x 40 mm depth is provided on each rear corner post so that 2 1/4" thick battens can be arranged to be able to prevent doors from damage due to shifting cargo.

4.11.4 Ventilator

Each container will have two small plastic ventilators of labyrinth type. Each ventilator is fixed to the right-upper part of each side wall by three 5.0mm dia. aluminum huck bolts in accordance with TIR requirements after drying of top coating, and caulked with sealant around the entire periphery except bottom to prevent the leakage of water.

5. Surface preservation

5.1 Surface preparation

- 1) All steel surfaces - prior to forming or after - will be fully abrasive shot blasted conforming to Swedish Standard SA2 1/2 to remove all rust, dirt, mill scale and all other foreign materials.
- 2) All door hardware will be hot-dipping zinc galvanized with approximately 75 microns thickness.
- 3) All fasteners such as self-tapping screws and bolts, nuts, hinges, cam keepers, lashing fittings will be electro-galvanized with approximately 13 microns thickness.

5.2 Primer coating

5.2.1 Prior to assembly

All steel surfaces will be coated with 10-15 microns thick two-pack polyamide cured zinc rich epoxy primer immediately after shot blasting, and then dried up in drying room.

5.2.2 After assembly

- 1) All weldments will be shot blasted to remove all welding fluxes, spatters, burnt primer coatings caused by welding heat, and other foreign materials.
Then all blasted weldments will be coated with zinc rich epoxy primer.
- 2) All of assembled container will be coated again 15-20 microns with zinc rich epoxy primer and again 40 microns epoxy primer prior to top coating for the exterior.

5.3 Top coating

- 1) After drying of primer, exterior of container will be coated again with high build top paint and interior will be coated again with polyamide cured epoxy resin based high build coating.
- 2) The dry film thickness of top coating will be 40 microns for the exterior and interior.

5.4 Under coating

After completion of flooring, all the understructures and floor will be coated with minimum 200 microns dry film thickness bituminous coating.

5.5 The total dry film will be (microns):

	EXT.	INT.	BASE
Zinc rich primer	30	30	30
Epoxy primer	40		
Epoxy high build coating(RAL 7035)		40	
Chlorinated rubber or Acrylic coating	40		
Bitumen			200
Total	110	70	230

6. Marking

6.1 Arrangement

The container will be marked in accordance with ISO, UIC, TCT, CSC and TIR requirements, owner's marking specifications and other required regulations.

6.2 Materials

- 1) Decal : - Self-adhesive, high tensile PVC film for seven (7) years guarantee without peeling off, tenting or colour fading.
- 2) Certification plate : 18-8 type stainless steel plates to be chemically etched by acid and treated by enamel.

6.3 Specifications

- 1) Identification plates such as consolidated data plate consisting of CSC, TIR and TCT will be riveted on the door permanently by stainless steel blind rivets. The entire periphery except underside will be caulked with sealant.
- 2) The owner's serial numbers and manufacturer's serial numbers will be stamped into the top plane of rear lower-left corner fitting.

7. Testing and Inspections

7.1 Testing

7.1.1 Prototype testing

The prototype container to be manufactured in accordance with this specification will be tested by manufacturer under the supervision of classification society.

	<u>Test items & loads</u>	<u>Test methods</u>
A)	Stacking Internal load : 1.8R-T Test load: 86,400kg/post	Hydraulic cylinder load will be applied to each corner post through top corner fittings. Offset: 25.4 mm lateral 38.0 mm longitudinal
B)	Lifting (from top corner fittings) Internal load : 2R-T	Lifting vertically. Time duration : 5 minutes
C)	Lifting (from bottom corner fittings) Internal load : 2R-T	Lifting 45 degree to the horizontal. Time duration : 5 minutes
D)	Lifting (for forklift pockets) Internal load : 1.6R-T	Lifting by horizontal bars. Bar length : 1,828mm Bar width : 200mm
E)	Restraint (longitudinal) Internal load : R-T Test load : 2R	Hydraulic cylinder load will be applied to the bottom side rails.
F)	Floor strength Test load : 7,260 kgs (16,000 lbs)	Use of a special truck. Total contact area: 284 sq. cm Wheel width : 180 mm Wheel centre : 760 mm
G)	Wall strength (front) Test load : 0.4(R-T)=0.4P	Compressed air bag will be used.
H)	Wall strength (side) Test load : 0.6(R-T)=0.6P	Compressed air bag will be used on one side only.
I)	Wall strength (door) Test load : 0.4(R-T)=0.4P	Same as front wall strength test.
J)	Roof strength (weakest part) Test load : 300 kgs	Applied area will be 600x300mm longitudinal and transverse.

20'X8'X8'6"

K)	Racking (transverse) Test load : 15,240 kgs	Hydraulic cylinder load will be applied to the header rail through top corner fittings.
L)	Racking (longitudinal) Test load : 7,620 kgs	Hydraulic cylinder load will be applied to the top side rail through top corner fitting on one side only. Two times for pulling and pushing.
M)	Operation of door	After completion of test, the operation of doors, locks, hinges, etc. will be checked.
N)	Dimensions and weight	After completion of test, the dimensions and weight will be checked.
O)	Weatherproofness	Inside dia. of nozzle : 12.5mm Distance : 1.5 m Speed : 100 mm/sec. Pressure : 1 kg/sq. cm

* Note: **R** Maximum Gross Weight
T Tare Weight
P Maximum Payload

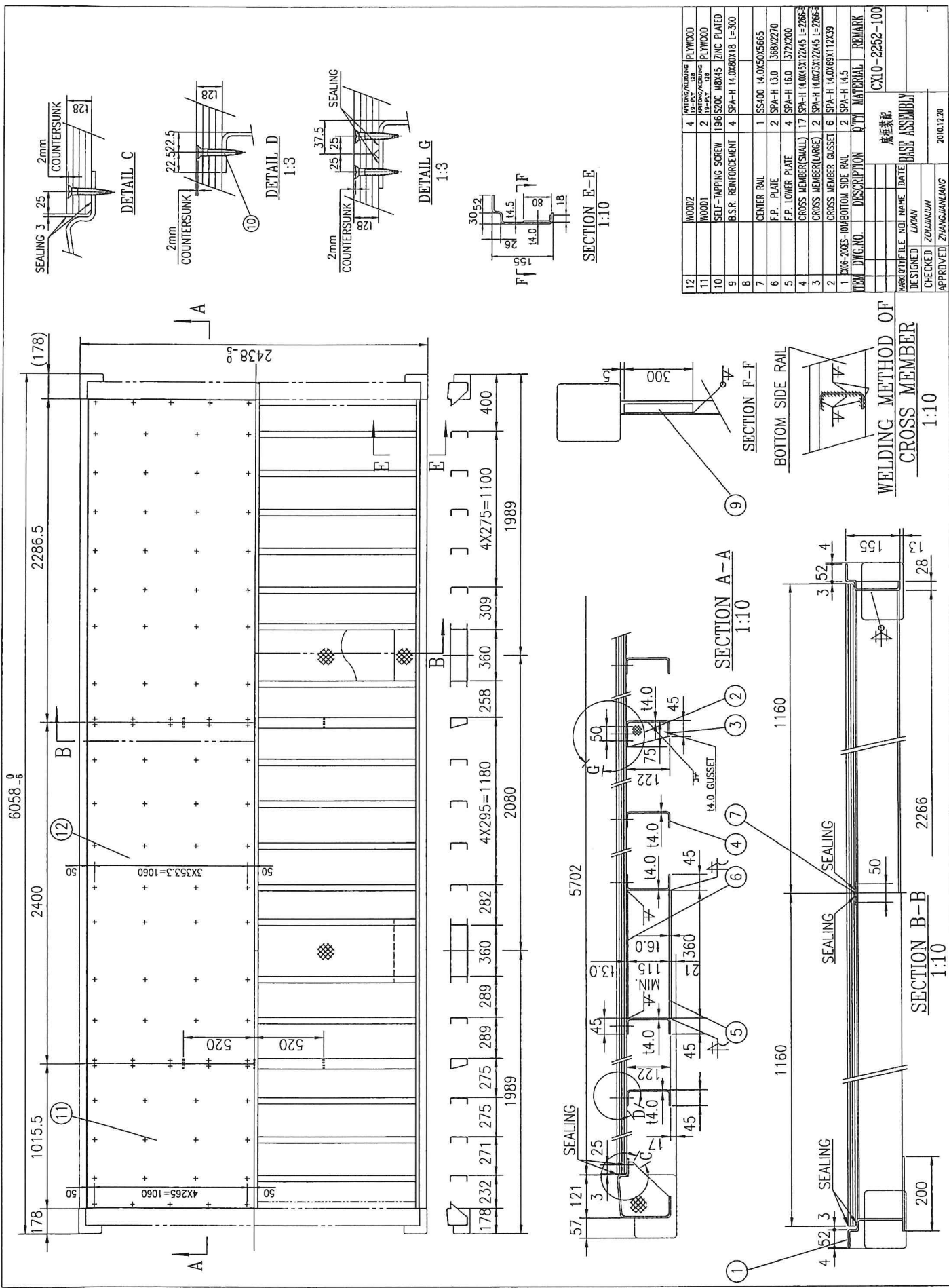

ITEM	QTY	DESCRIPTION	UNIT	MATERIAL	REMARK
12	1	WOOD2	1	PLYWOOD	
11	2	WOOD1	2	PLYWOOD	
10	1	SELF-TAPPING SCREW	196	S20C M8X45 ZINC PLATED	
9	4	B.S.R. REINFORCEMENT	4	SPA-H 14.0X50X18 L=300	
8	1	CENTER RAIL	1	SS-400 14.0X50X5665	
7	2	F.P. PLATE	2	SPA-H 13.0 36RX2770	
6	4	F.P. LOWER PLATE	4	SPA-H 16.0 372X2200	
5	17	CROSS MEMBER(SMALL)	17	SPA-H 14.0X50X12245 L=2266	
4	2	CROSS MEMBER(LARGE)	2	SPA-H 14.0X75X12245 L=2266	
3	6	CROSS MEMBER GUSSET	6	SPA-H 14.0X50X11239	
2	2	TOP/BOTTOM SIDE RAIL	2	SPA-H 14.5	
1	1	206-2063-10/BOTTOM SIDE RAIL	1		
					REMARK
					CX10-2252-100
					成龍裝配
					BASE ASSEMBLY
MARKET FILE NO. NAME DATE					
DESIGNED LU YAN					
CHECKED ZOU JIUN					
APPROVED ZHANG JIAN LIANG					
					2010.12.20

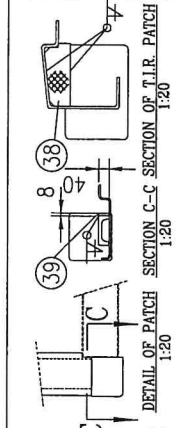

50	HUCK BOLT	6	S45C #10X19/30 5/1
49	CORNER FITTING	4	SCW#80
48	ROPE	2	NYLON #6
47	GUSSET	2	SPA-H 14.0X200X55 L=63
46	CHANNEL STEEL	2	SS400 200X25X9.0 L=65
45	LASHING BAR	4	SS400 #10 ZINC PLATED
44	BLIND RIVET	84	SUS304 #4.8
43	GASKET RETAINER	4	SUS304
42	GASKET RETAINER	3	SUS304
41	GASKET	1	E.P.D.M. R. J.-C-TYPE
40	GASKET	1	E.P.D.M. L. J.-C-TYPE
39	PATCH	2	SPA-H 16.0 40X49
38	T.I.R. PATCH	2	SPA-H 13.0
37	STOPPING PLATE	1	SPA-H 14.0
36	HINGE PIN	8	SUS304 #12
35	HINGE BUSH	16	NYLON
34	HINGE WASHER	8	BRASS 11.5
33	HINGE LUG	16	SS400 18.0
32	HINGE BRAD	8	S25C
31	RETAINER BUSH	4	SS400
30	HANDLE RETAINER	4	SS400
29	HANDLE RETAINER	4	SS400
28	HANDLE RRET	4	S10C
27	HANDLE HINGE	4	SS400
26	HANDLE	4	S25C
25	B.I.W.	4	S25C
24	BRACKET BUSH	20	NYLON
23	BRACKET BUSH	20	NYLON
22	SHIM	8/8	E.P.D.M.
21	BEARING BRACKET	4	SS400
20	BEARING BRACKET	4	SS400
19	BEARING BRACKET	8	SS400
18	BEARING BRACKET	8	SS400
17	ANTI-RACKING RING	16	SS400
16	LOCK DAM KEEPER	2	S25C
15	LOCK DAM	2	S20C
14	LOCKING ROD	4	SIRKID #3030 GALV.
13			
12			
11	PATCH	8	SPA-H 13.0 98X48
10	SQUARE TUBE(INNER)	4	SPA-H 100X50X3.7 L=748
9	HORIZONTAL MEMBER	4	SPA-H 13.0X50X3.0X50 L=943
8	DOOR PANEL	2	SPA-H 12.0
7	DOOR HEADER GUSSET	4	SPA-H 14.0
6	DOOR HEADER(UPPER)	1	SPA-H 13.0
5	DOOR HEADER(LOWER)	1	SPA-H 14.0
4	DOOR SILL GUSSET	4	SPA-H 14.0
3	DOOR SILL	1	SPA-H 14.5
2	CORNER POST(INNER)	2	SMA90A 110 L=2355
1	CORNER POST(OUTER)	2	SPA-H 16.0

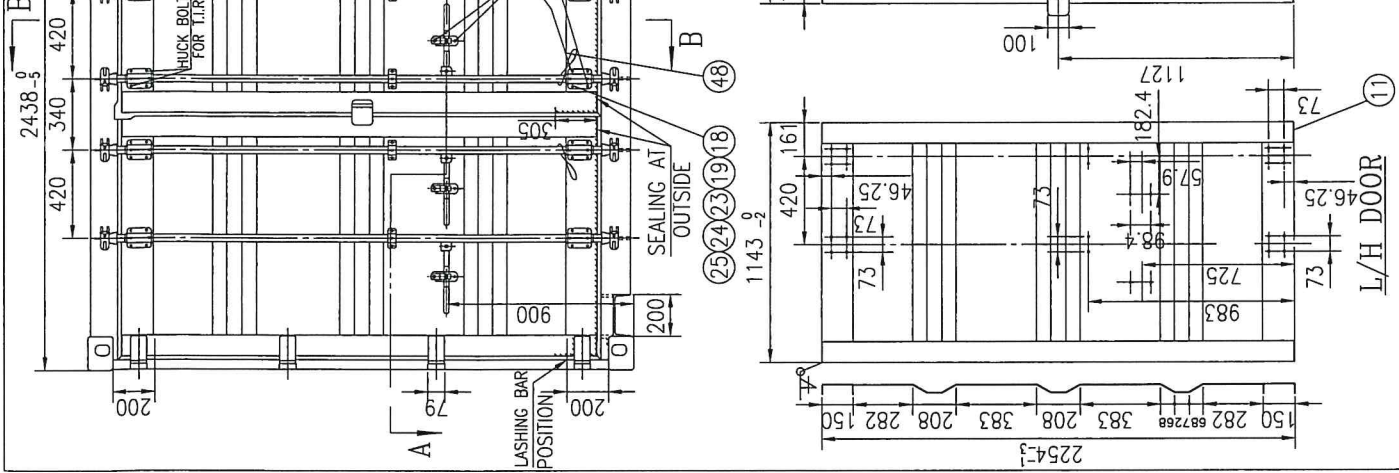
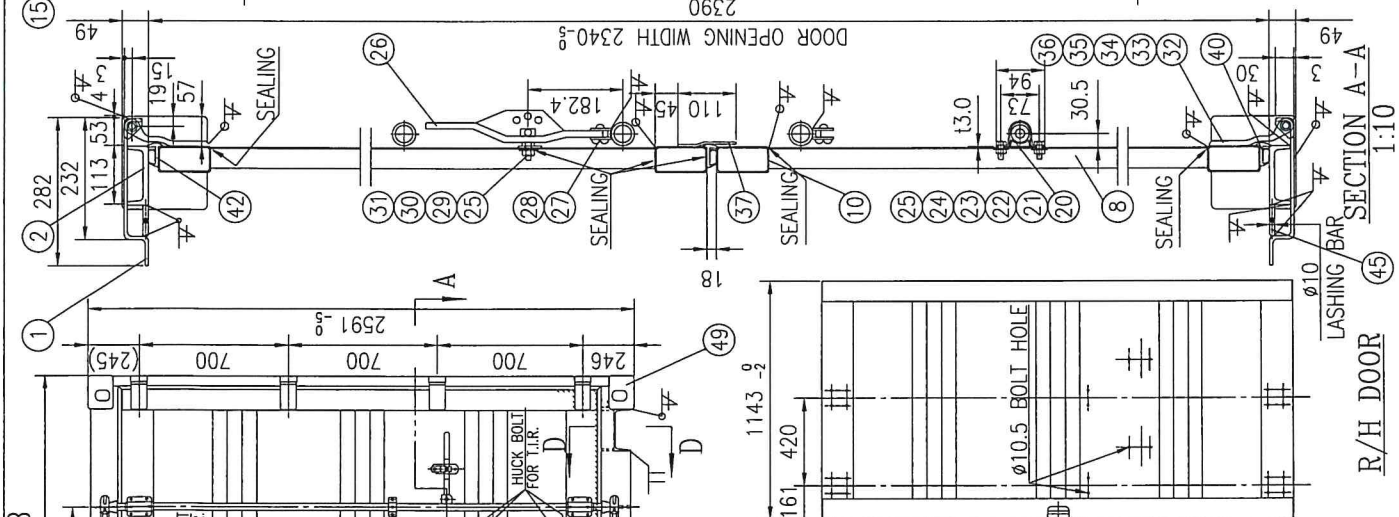
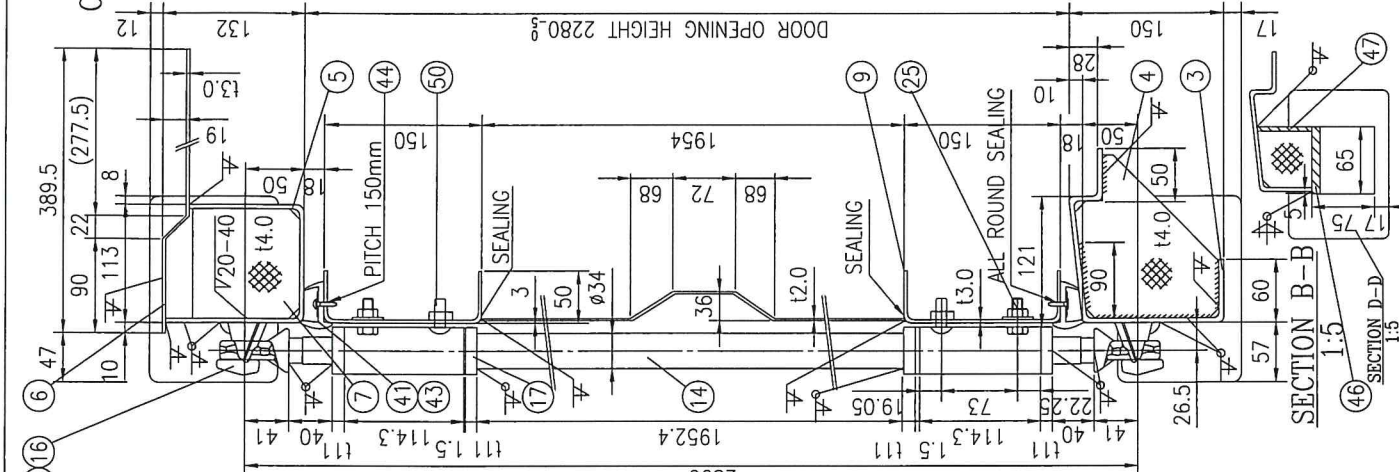

APPROVED		Zheng Ji		2011.12.20	
CHECKED	Zou Ji	DESIGNED	LIXIAO	DATE	
DRAWING NO.		DESCRIPTION		MATERIAL	
CX10-2052-200		门端装配		DOOR ASSEMBLY	
REMARK		CX10-2052-200			

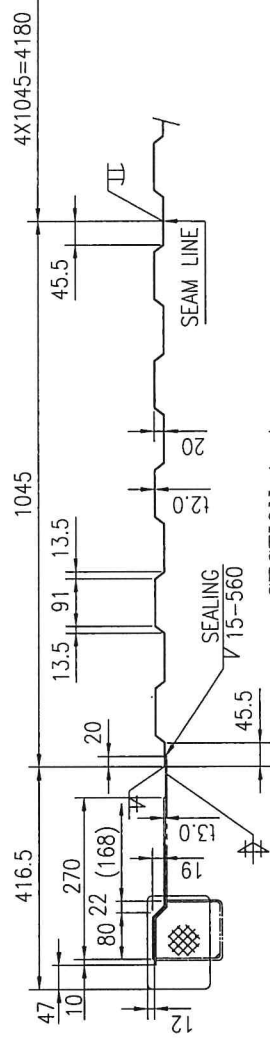
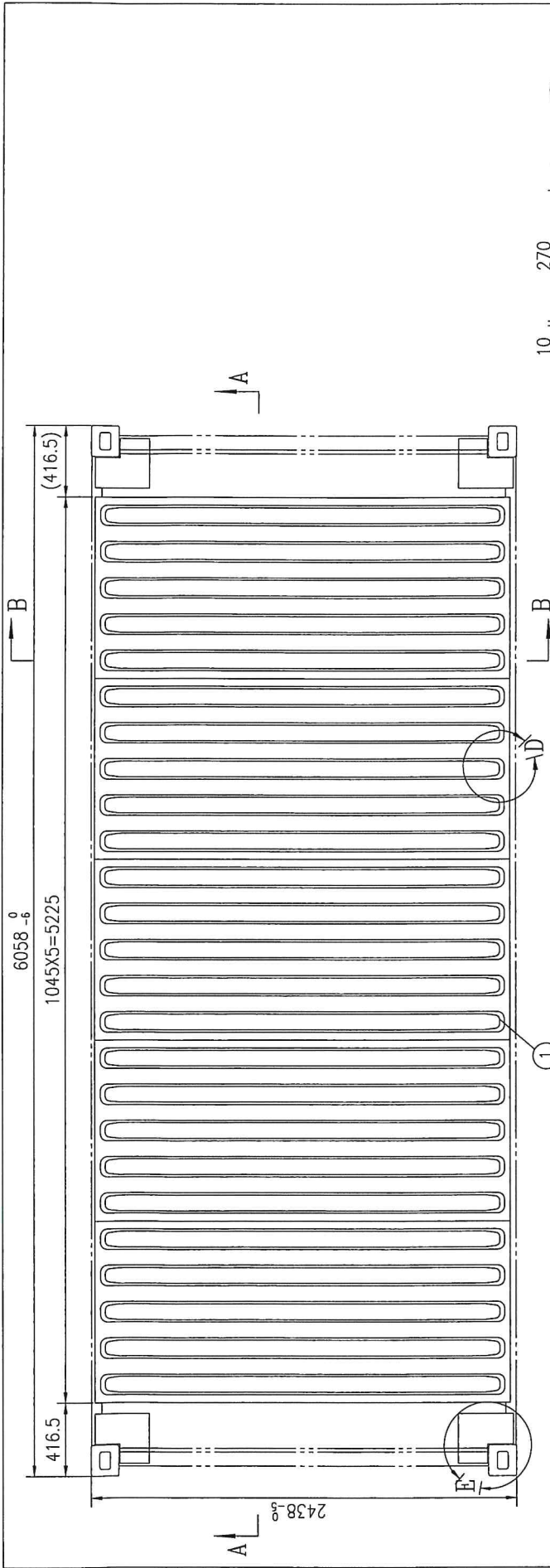

SECTION A-A
1:10

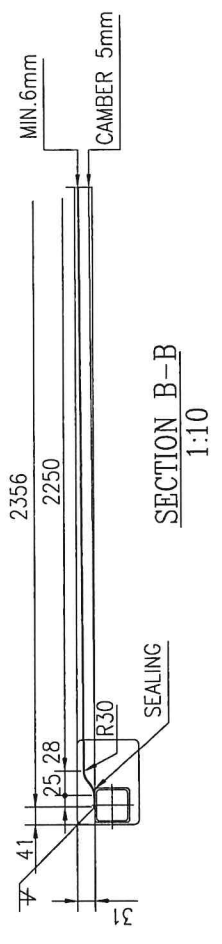

SECTION B-B
1:10

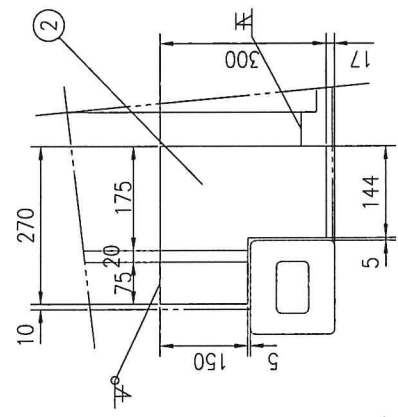

DETAIL E
1:10

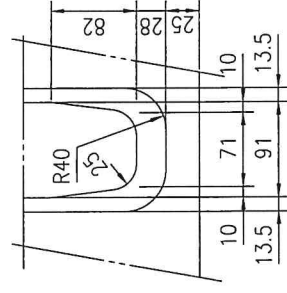

DETAIL D
1:5

2	ROOF GUSSET (REAR)	5/8" SPA-H 13.0	
1	ROOF PANEL	5 SPA-H 12.0	
ITEM	QTY	DESCRIPTION	REMARK
		PTI MATERIAL	CX10-2252-300
		设计人	
		审核人	
		ROOF ASSEMBLY	
		DESIGNED	
		DATE	
		LXW	
		CHECKED	
		Zou JJ	
		APPROVED	
		Zhang JL	
			2011.12.20

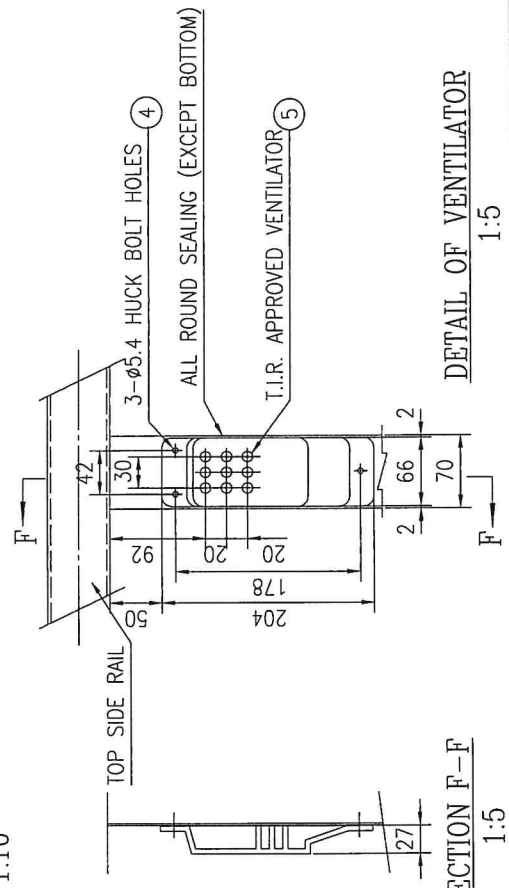
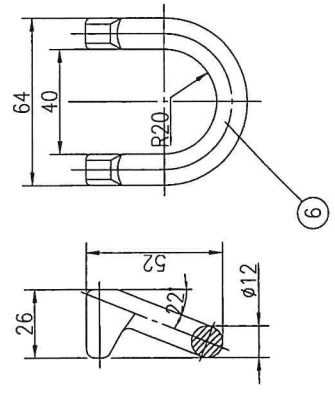
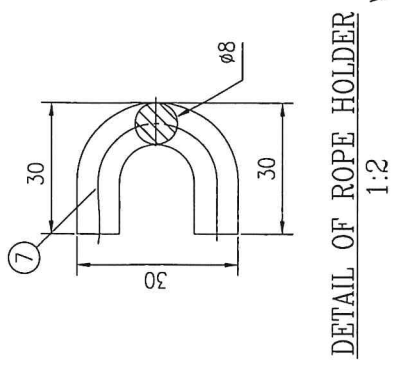
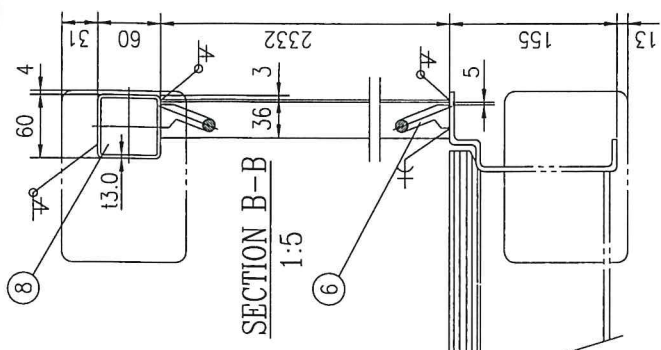
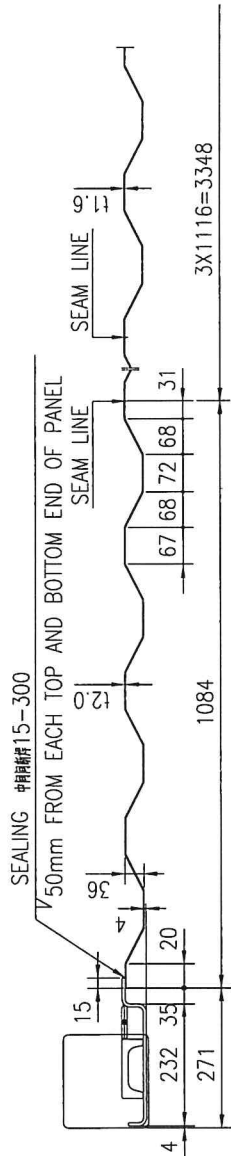
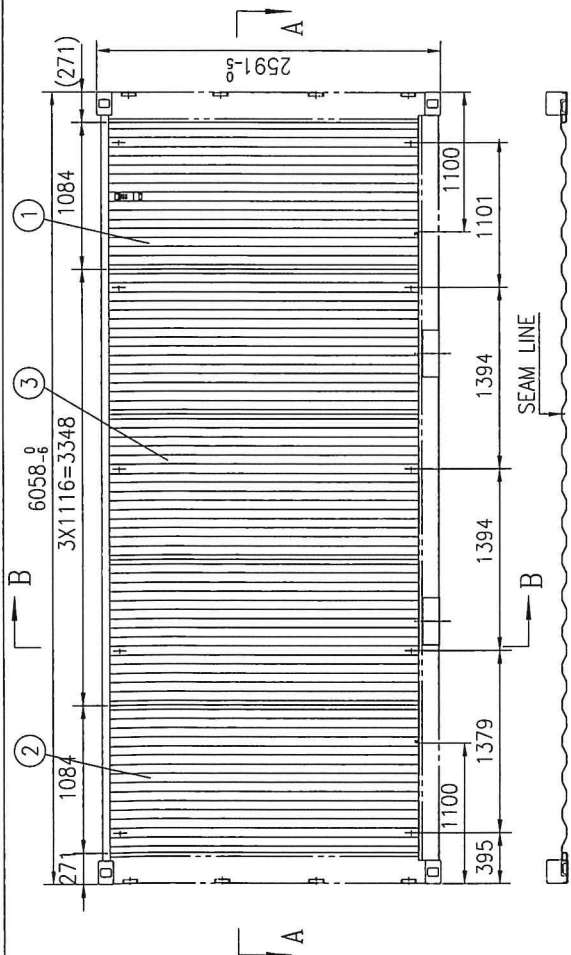

DETAIL OF VENTILATOR
1:5

SECTION F-F
1:5

8	TOP SIDE RAIL	2	SPA-H 6060X130 L=5702
7	ROPE HOLDER	4	SS400 #8 ZINC PLATED
6	LASHING RING	20	SS400 #12 ZINC PLATED
5	VENTILATOR COVER	2	ABS
4	HUCK BOLT	6	M 45
3	SIDE PANEL(INNER)	6	SPA-H 11.6 L=116823323
2	SIDE PANEL(OUTER)	2	SPA-H 12.0 L=108423323
1	WITH VENT	2	SPA-H 12.0 L=108423323
1	WITHOUT VENT	2	SPA-H 12.0 L=108423323
ITEM	QTY	MATERIAL	REMARK
			CX10-2252-400
神戶製鐵			
WORKS/FILE NO.	NAME	DATE	SIDE ASSEMBLY
CHECKED	Zou JJ		
APPROVED	Zhang JJ	2011.12.20	